



DIVISION: 31 00 00—EARTHWORK
Section: 31 60 00—Special Foundations and Load-Bearing Elements

REPORT HOLDER:

AG-CO PRODUCTS, INC.

EVALUATION SUBJECT:

AG-CO FOOTINGPAD® MODELS FP-10, FP-12, FP-16, FP-20 AND FP-24

1.0 EVALUATION SCOPE

Compliance with the following codes:

- 2021, 2018, 2015, 2012, 2009 and 2006 *International Building Code*® (IBC)
- 2021, 2018, 2015, 2012, 2009 and 2006 *International Residential Code*® (IRC)

Properties evaluated:

- Structural
- Durability

2.0 USES

The AG-CO FootingPad® models FP-10, FP-12, FP-16, FP-20 and FP-24 are used as footings for the support of post columns in buildings for Type V construction under the IBC or any construction under the IRC. The FootingPad® post foundations are used as individual, isolated footings supporting gravity loads only.

3.0 DESCRIPTION

The AG-CO FootingPad® models FP-10, FP-12, FP-16, FP-20 and FP-24 are molded composite footings manufactured from a proprietary composite of engineered polypropylene and fiberglass. The FootingPad® post foundations are circular, ribbed-plastic pads formed by an injection molding process. See Figures 1, 2, 3, 4 and 5 for dimensions and rib configurations.

4.0 DESIGN AND INSTALLATION

4.1 Design:

The FootingPad® post foundations are designed as shallow rigid footings that transmit, uniformly to the supporting soil, the applied gravity load imposed by a minimum 3½-inch by 3½-inch (89 mm by 89 mm) post on the FP-10 pad, a minimum 3½-inch-by-3½-inch (89-mm-by-89-mm) post on

the FP-12 pad, a minimum 4½ inch by 5½ inch (114 mm by 140 mm) post on the FP-16 pad, a minimum 4½ inch by 5½ inch (114 mm by 140 mm) post on the FP-20 pad and a minimum 4½-inch-by-5½-inch (114-mm-by-140-mm) post on the FP-24 pad. The posts must have a solid base bearing on the pads. Allowable loads are controlled by the type of supporting soil. The post foundations design load must not exceed the allowable gravity loads shown in Table 1.

4.2 Installation:

The post location or spacing must be determined by the loads imposed on the post and the FootingPad® post foundation allowable load for the specific type of soil (see Table 1). The post hole must be slightly larger than the post foundation diameter and deep enough to satisfy all design requirements. The bottom of the hole must be flattened and leveled to provide a uniform bearing surface for the FootingPad® post foundation. The FootingPad® post foundations must be placed into the hole with the flat side down. The footing must be tamped until level and stable in the bottom of the hole. The square-cut-post end must be positioned as close as possible to the center of the FootingPad® post foundation and the post must be plumbed. The dirt around the post must be placed in 12-inch lifts (30.5 cm), tamping each lift before more soil is added.

5.0 CONDITIONS OF USE

The AG-CO FootingPad® models FP-10, FP-12, FP-16, FP-20 and FP-24 described in this report comply with, or are suitable alternatives to what is specified in, those codes listed in Section 1.0 of this report, subject to the following conditions:

- 5.1** Installation must comply with this report, the applicable code and the manufacturer's published installation instructions. If there is a conflict between the manufacturer's installation instructions and this report, this report governs.
- 5.2** The FootingPad® post foundations are used to support post columns for Type V construction under the IBC or any construction under the IRC.
- 5.3** The FootingPad® post foundations must be installed below the frost line of the locality.
- 5.4** The FootingPad® post foundations must be used as individual isolated footings to resist bearing loads only and must not be used to resist lateral or uplift loads.
- 5.5** The design of the structure supported by the FootingPad® post foundations is outside the scope of this report.

6.0 EVIDENCE SUBMITTED

Data in accordance with the ICC-ES Acceptance Criteria for Molded Plastic Footing Pads (AC49), dated August 2013 (editorially revised May 2021).

7.0 IDENTIFICATION

7.1 Each FootingPad® post foundation must have a permanent label or etching including the name of the manufacturer, the model number and the evaluation report number (ESR-2147).

7.2 The report holder's contact information is the following:

AG-CO PRODUCTS, INC.
400 CAROL ANN LANE
OSSIAN, INDIANA 46777
(800) 522-2426
www.footingpad.com

TABLE 1— FOOTINGPAD® POST FOUNDATION ALLOWABLE LOADS (POUNDS) RELATED TO LOAD-BEARING PRESSURES OF FOUNDATION MATERIALS

FOOTINGPAD® MODEL	PAD DIAMETER	LOAD-BEARING PRESSURES OF FOUNDATION MATERIALS ¹			
		1500 psf	2000 psf	2500 psf	3000 psf
FP-10	10 inch	810 lbs.	1081 lbs	1351 lbs	1622 lbs.
FP-12	12 inch	1126 lbs.	1536 lbs	1946 lbs	2356 lbs.
FP-16	16 inch	2009 lbs.	2739 lbs	3470 lbs	4200 lbs.
FP-20	20 inch	2687 lbs.	3973 lbs	5259 lbs	6545 lbs.
FP-24	24 inch	4013 lbs.	5784 lbs	7556 lbs	9327 lbs.

For **SI**: 1 inch = 25.4 mm; 1 lbf = 4.4 N; 1 lbf/ft² = 47.9 Pa.

1. Load-bearing pressures of foundation materials shall be determined using the presumptive load-bearing values in IBC Table 1806.2 or IRC R401.4.1, as applicable, or the load-bearing values shall be determined with a site-specific soil investigation, as required by the code official.

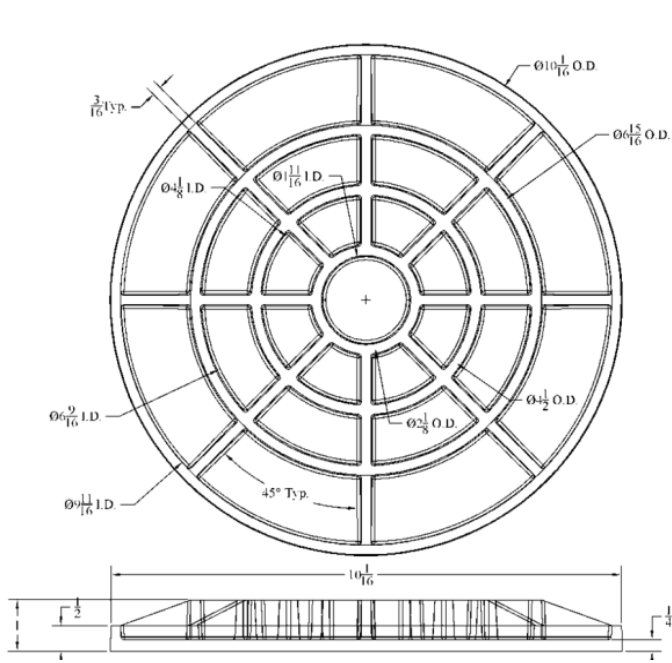

(All Dimensions in inches)
FIGURE 1—FP-10 FOOTINGPAD®

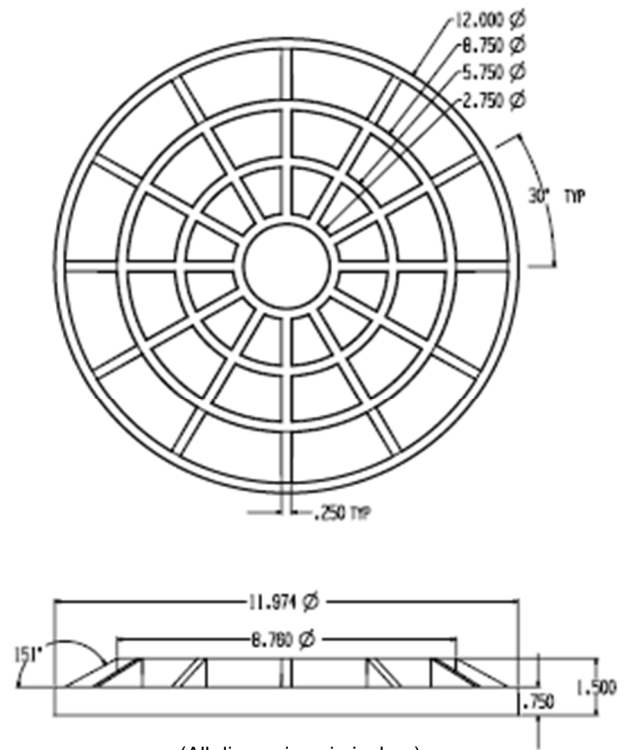

(All dimensions in inches)
FIGURE 2—FP-12 FOOTINGPAD®

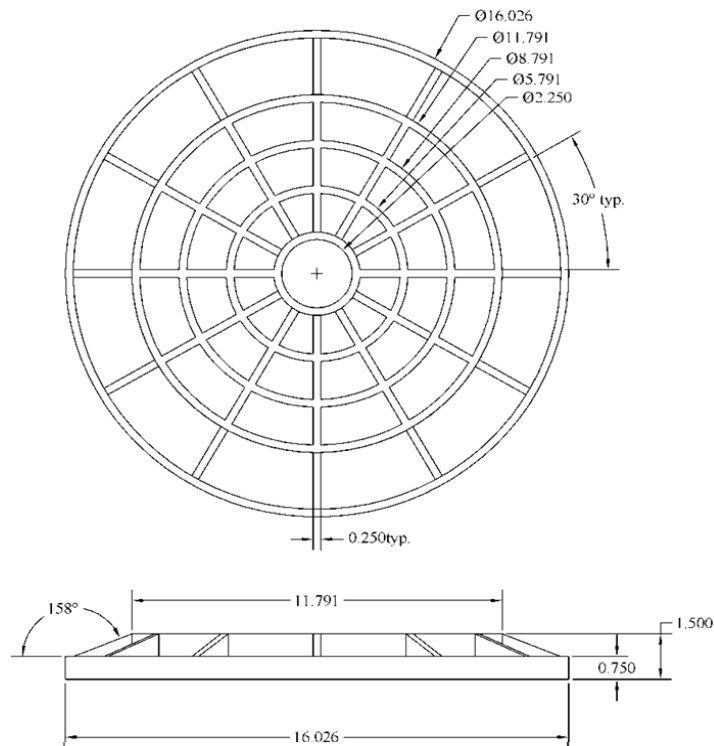

(All Dimensions in inches)
FIGURE 3—FP-16 FOOTINGPAD®

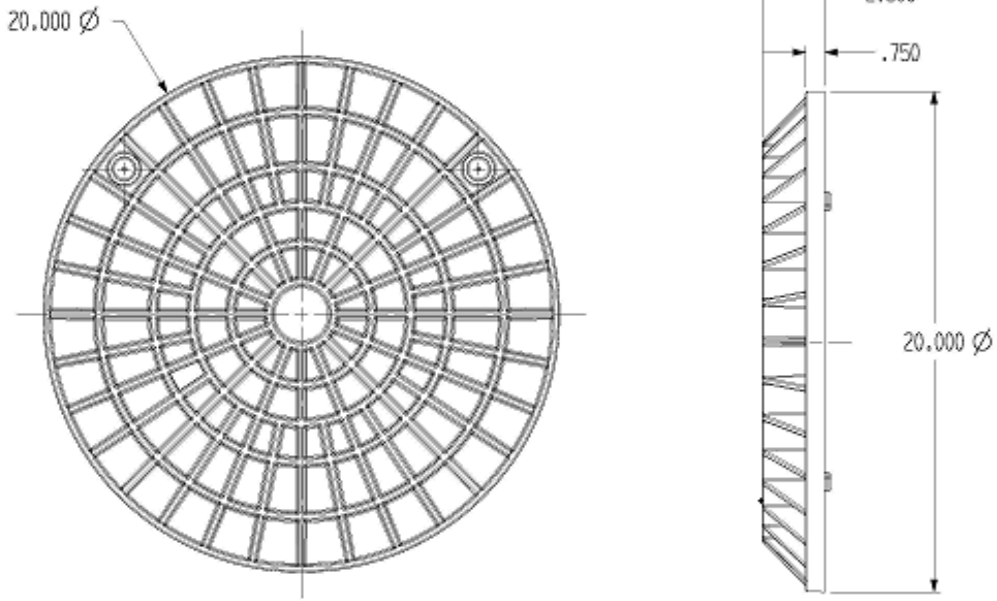

(All Dimensions in inches)
FIGURE 4—FP-20 FOOTINGPAD®

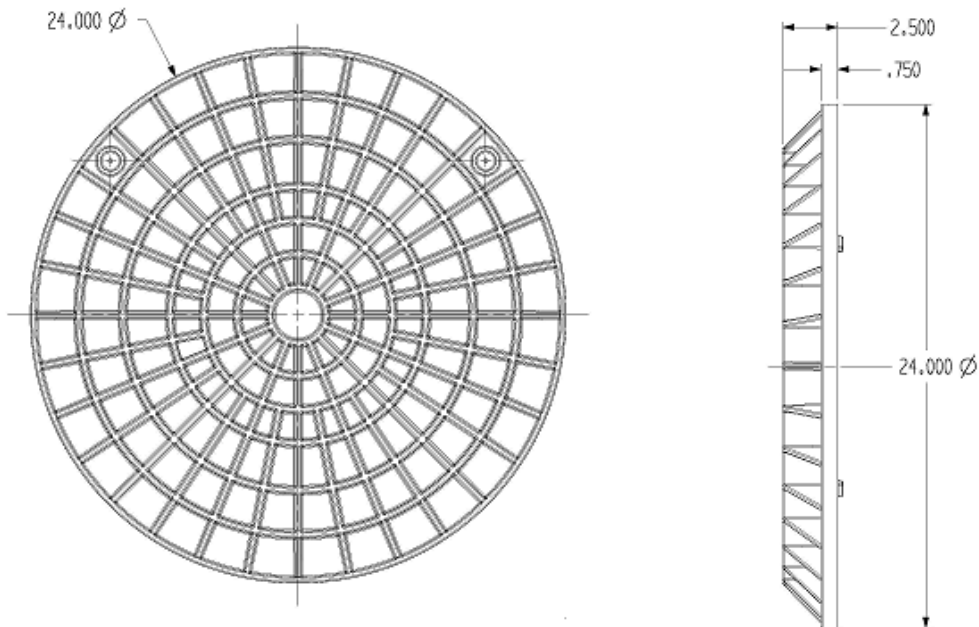

(All Dimensions in inches)
FIGURE 5—FP-24 FOOTINGPAD®